

Vireo HR185WM

The Vireo HR185WM is a heat recovery unit designed to enable better and easier specification of ventilation in new properties. It contains features such as its automatic true summer by-pass, high heat recovery efficiency and integrated humidity sensor to provide a comfortable, healthy and energy efficient indoor climate.



GRC1 Speed controller



GS2 Switch

Key Features

- Left or right hand configuration through software alone, no mechanical alteration required.
- 100% full and filtered summer bypass.
- Modern, discreet design.
- Easy installation to wall, cupboard or tallboy kitchen cupboard.
- Light to handle.
- BMS capability.
- Tool free filter access.
- Volt free contact boost capability.
- CommissionSMART™ is a commissioning wizard that enable a quick and simple set-up process.
- SummerSMART™ ensures automatic full by-pass activation providing filtered supply air 365 days a year.
- TimerSMART™ eliminates nuisance noise and over-ventilation by determining the duration of occupancy and allocating a suitable overrun time.
- HumidiSMART™ continuously monitors the humidity level within the home and looks for a man-made spike before boosting the unit, irrespective of distance or dilution.

SAP PCDB Test Results

	SFP (W/l/s)		Efficiency (%)	
	2009	2012	2009	2012
K+1	0.60	0.57	92%	92%
K+2	0.57	0.64	92%	91%
K+3	0.62	0.76	91%	91%
K+4	0.70	0.96	91%	91%
K+5	0.81		91%	
K+6	0.95		91%	
K+7	1.14		90%	

SEC Class



Based on average climate with local demand control

Article Numbers

Description	Product Code
Vireo HR185WM for wall or cupboard mounting with SMART technology	HR185WM
Controls, two position switch for Vireo and Centair range	GS2
Controls, duel speed controller for Vireo range with operational and service indicators	GRC1

Article Numbers

Description	Product Code
Controls, remote air quality sensor	AQR
Controls, remote humidity sensor	HHRW
Controls, remote passive infra-red movement sensor	PIRR
Controls, remote temperature sensor	THR
Filter set for Vireo HR185WM, G3, 2 pack	HR185FIL
Heat exchanger for Vireo HR185WM	HR185EX

Technical Specification

Weight	30Kg
Ducting ø	150 mm
Condensate connection ø	21.5 mm
Filter grade	G3
Materials	Internal PP/EPS External ABS
Supply voltage	230V / single-phase / 50Hz
Maximum power consumption	170 W
Current draw	1.2 amp
Fuse	3 amp
Specific Fan Power	0.57 W/l/s
Heat Recovery Efficiency	92%

Dimensions

Height	899 mm
Width	550 mm
Depth	555 mm

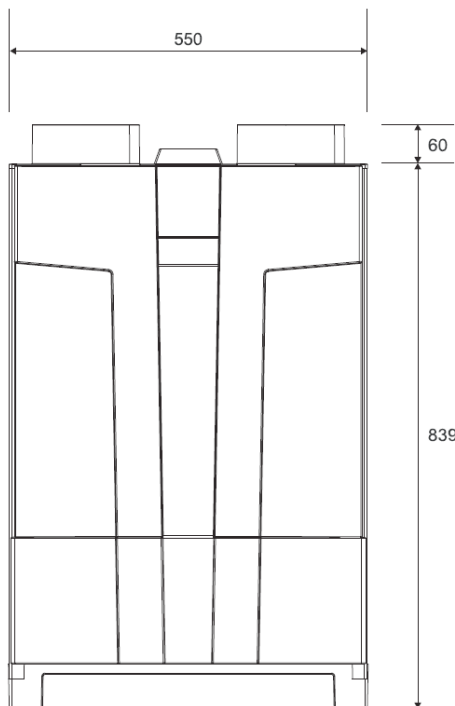

Front View

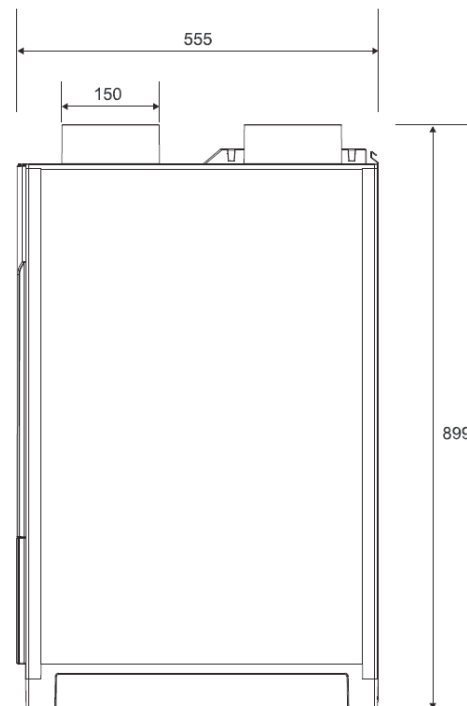

Side View

Pressure Curve

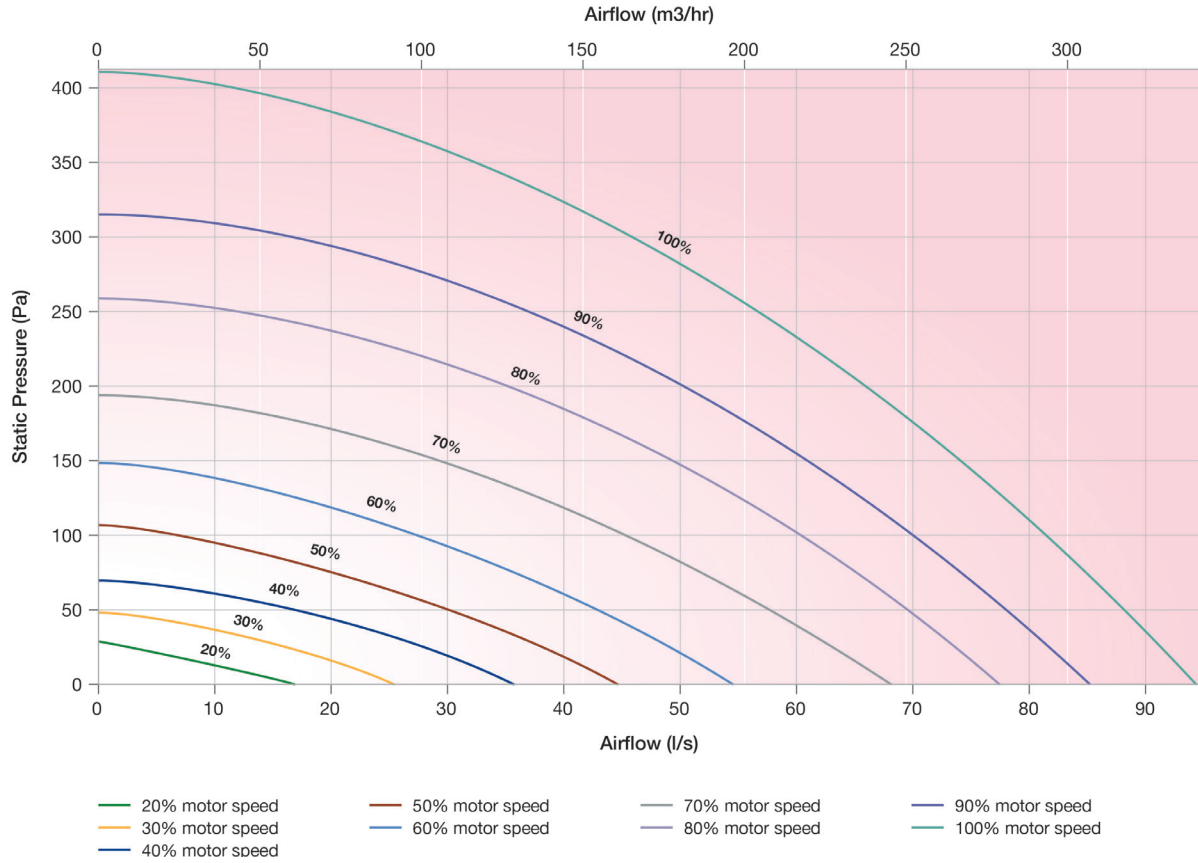

Sound Data

Speed	Test Area	Octave Band (Hz) Sound Power Level, dB								dB(A)@3m
		63	125	250	500	1000	2000	4000	8000	
20%	Casing	32.8	33.9	34.7	30.0	25.6	18.3	18.0	24.0	14.5
	Supply/Exhaust	52.7	41.8	37.8	34.7	26.3	17.0	18.2	24.3	
	Extract/Intake	56.1	40.3	35.4	23.8	16.6	13.4	18.2	24.3	
40%	Casing	40.3	45.2	45.0	43.2	38.4	30.0	21.7	24.1	26.0
	Supply/Exhaust	64.6	54.2	49.6	50.3	44.8	37.2	31.0	26.4	
	Extract/Intake	53.6	49.3	46.8	37.2	31.0	22.4	19.7	24.3	
60%	Casing	47.9	54.5	52.7	50.5	48.4	41.1	33.2	26.3	35.0
	Supply/Exhaust	70.2	62.4	57.0	58.0	55.5	49.3	44.9	39.0	
	Extract/Intake	59.5	57.9	54.2	44.9	40.8	43.2	28.9	25.8	
80%	Casing	52.4	60.8	59.2	56.1	54.9	48.8	41.0	32.1	41.0
	Supply/Exhaust	76.0	69.1	63.3	63.0	62.0	57.0	52.9	48.0	
	Extract/Intake	64.3	64.2	60.4	50.5	47.0	42.0	37.0	30.9	
100%	Casing	56.4	65.1	63.7	60.3	59.2	53.8	46.5	38.1	45.5
	Supply/Exhaust	80.3	72.9	68.0	67.2	66.8	62.4	58.6	54.2	
	Extract/Intake	68.5	68.3	65.4	54.5	51.5	47.4	42.6	36.5	

Tested according to BS EN 13141-7:2010. Supply and Extract showing induct sound power level. Casing dBA @ 3m given as hemispherical.

Air Direction/Connection

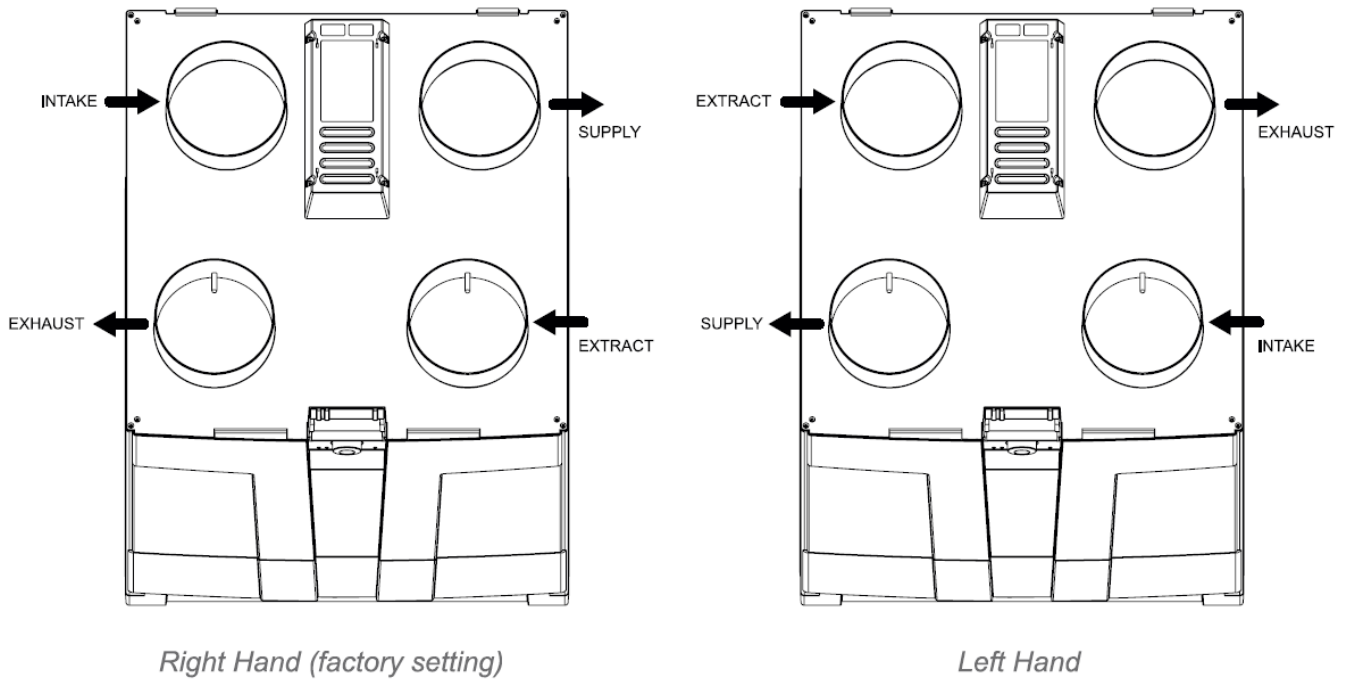

Wiring

Electrical connections should be carried out in accordance to IEE regulations by a qualified electrician. The unit is supplied with a flying lead for connection to the mains supply.

Two speed control via GS2 switch

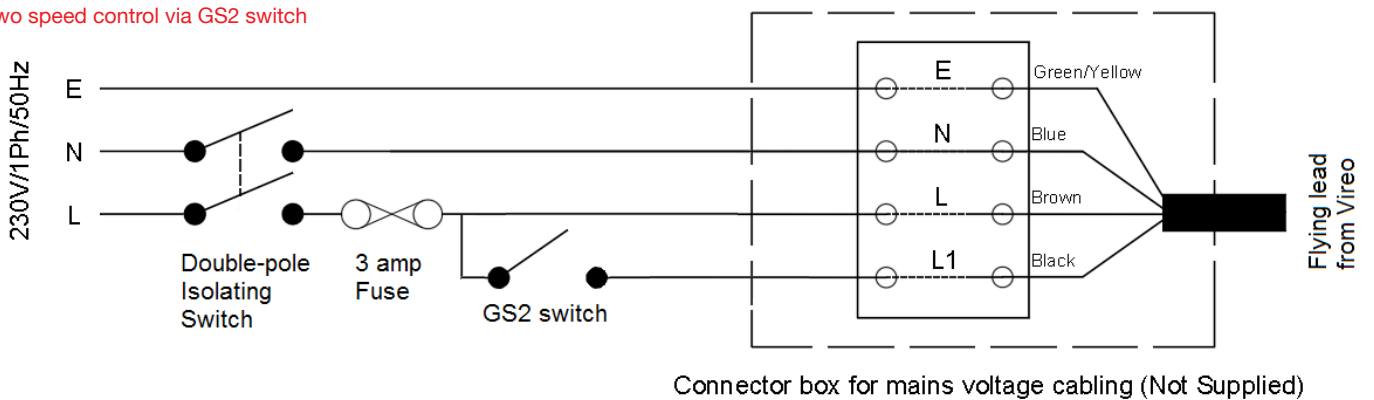

Wiring

Two speed control via light switch

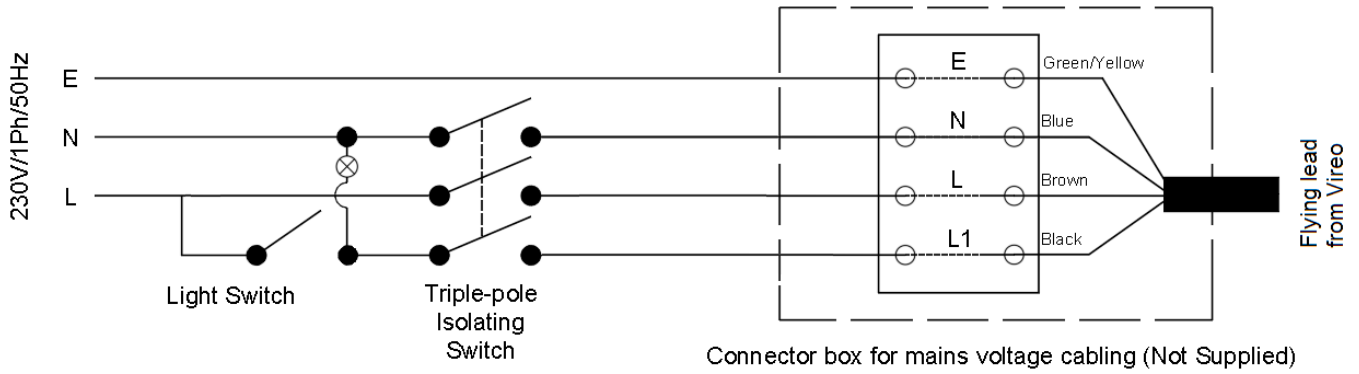

Two speed control via remote sensor

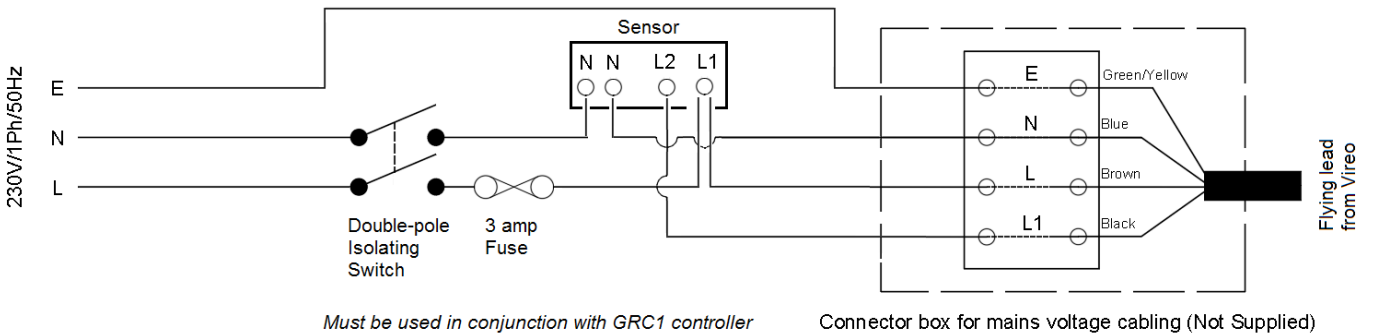

Two speed control via GRC1 switch

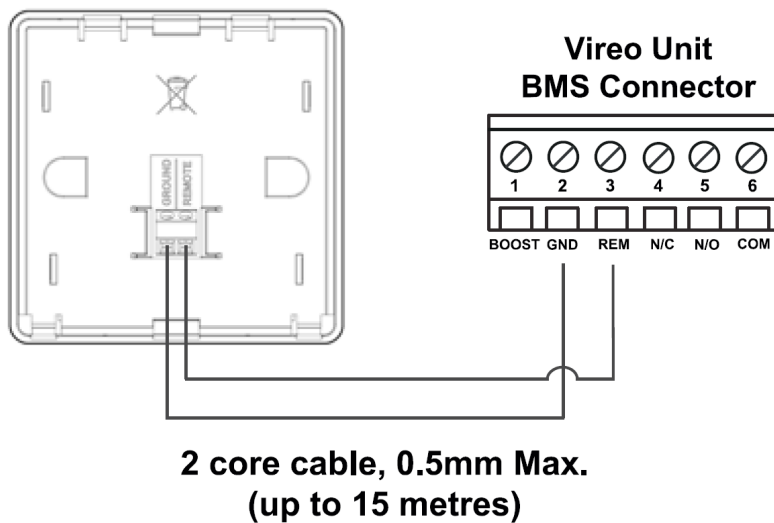

Consultant specification

Vireo + BMS connection

ELECTRICAL CONNECTION / TERMINAL DIAGRAM

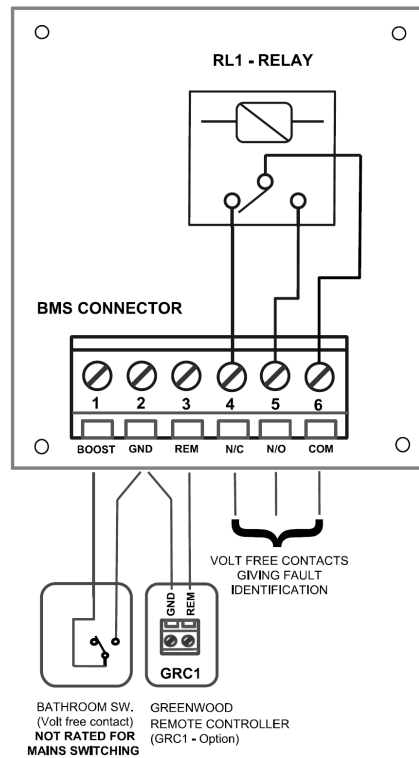

Consultant specification

Specification

The unit shall consist of a body manufactured in recyclable ABS. The unit shall be fully insulated with EPS to maintain excellent thermal characteristics. It shall have EC low energy motors with sealed for life bearings. The fan shall have a forward curved centrifugal impellor. The heat exchanger shall be a multi-plate, counter flow design constructed from Polystyrene with laser welded joints and shall retain up to 92% of the temperature differential of outgoing air.

The unit shall contain filters manufactured from synthetic material which has been tested to a minimum of G3 standard. The filters shall be pleated to reduce the pressure drop whilst increasing the time between maintenance requirement. The unit shall have 150mm duct connections and be suitable for ceiling mounting with the ability to allow left or right hand configuration through the unit's software alone – no mechanical reconfiguration shall be required. The unit shall be compatible with air conditioning systems as condensate can be taken from both sides of the product simultaneously.

The unit shall have 100% full summer by-pass and provide filtered supply air 365 days of the year, even under bypass conditions. The unit shall contain a temperature sensor for each air stream to ensure correct and logical operation of the bypass damper by evaluating differential as well as absolute temperature to maximise the opportunity for free cooling.

The unit shall be constructed to have a removable cover to allow full maintenance access.

The unit shall conform to LVD and EMC standards and be CE Marked in addition to having an EU compliant energy rating label (SEC) with a minimum grade of A. The unit shall be manufactured by Zehnder.

Consultant specification

Operation

The supply and extract unit shall be a Vireo manufactured by Zehnder and shall be suitable to mount on a wall or in a cupboard in accordance with the specification.

The fresh filtered air from outside shall be supplied to each of the habitable rooms and pre-heated by the warm extract air from the wet areas, such as kitchen or bathroom, via the plastic counter flow heat exchanger. The unit shall vary its speed of the EC motors automatically when it receives a signal from one of the inbuilt sensors or via external switches.

The unit shall have the ability to adjust and commission the supply and extract motors independently via the front mounted in-built LCD interface. The motors shall both offer 100% variable speed control.

Controls

All Vireo units shall contain the following functions within the unit pre-wired and factory fitted by the manufacturer:

- 100% variable supply and extract motor control
- Variable low and high speed flow rate set point
- BMS compatibility offering speed control and status indication
- Switched live input
- Volt free contact
- Automatic filtered summer bypass with timed manual override option
- Heat exchanger frost protection
- Commissioning wizard to enable commissioning of the unit in just 8 simple steps
- Integral service, fault and operation indicators
- Control panel PIN protection
- Tool free filter access
- Runtime counter
- Humidity sensors to operate the unit in response to humidity spikes above natural background humidity levels as opposed to a single threshold humidity point to activate the high set point
- Variable overrun timer relative to high speed activation period

zehnder
always the
best climate